

Wood Power

Combine renewable resources with renewable energy!



Aesthetic Design meets high Power Generation

stable wooden construction in combination with transparent double glass modules

Wood structure

All components consist of high-quality solid structural timber (KVH). Dry material with low cracking and shrinkage. The construction is carried out according to our statics for the customers snow load zone.

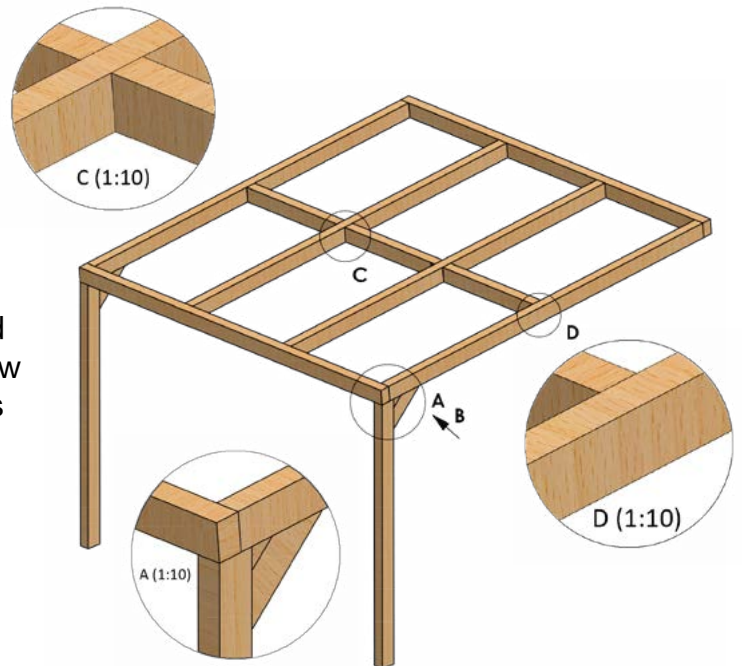

Colour design

For a small surcharge you get the construction with 2 protective coats and 2 coats of paint in 3 different standard colours (white, grey or dark brown). Other RAL colours on request.



Kit

The individual wooden parts are supplied numbered as a kit with detailed assembly instructions. Due to the exact cutting of the wooden profiles, the construction can be erected in the shortest possible time. The individual wooden beams are connected with the supplied screws.

The construction is available in terrace and carport versions.



Carport XXL-W

Technical data

Name	Terraces						Carports		
	LEA3-W	LEA4-W	EVA3-W	EVA4-W	MILA3-W	MILA4-W	M-L-W	L-W	XXL
depth [m]	2.03	2.03	3.34	3.34	3.97	3.34	4.01	5.05	5.05
width [m]	3.10	4.10	3.10	4.10	3.10	4.10	3.10	3.10	5.11
front height [m]	2.40	2.40	2.40	2.40	2.40	2.40	2.28	2.37	2.37
rear height [m]	(depending on construction angle)	(depending on construction angle)	(depending on construction angle)	(depending on construction angle)	(depending on construction angle)	(depending on construction angle)	1.93	1.93	1.93
Recommended Modules	3 x M72 (370 Wp)	4 x M72 (370 Wp)	6 x M60 (310 Wp)	8 x M60 (310 Wp)	6 x M72 (370 Wp)	8 x M72 (370 Wp)	6 x M72 (370 Wp)	9 x M60 (310 Wp)	15 x M60 (310 Wp)
Output	1.1 kW	1.5 kW	1.8 kW	2.5 kW	2.2 kW	3.0 kW	2.2 kW	2.8 kW	4.7 kW

Data are approximate values

Individual Solutions

Wood is a natural renewable material and extremely versatile in its use. Our customers have therefore been using wood for many years and appreciate the fact that our modules can easily be integrated into such constructions in a watertight manner. The pictures below show some of the beautifully designed solutions, from terraces in private houses to outside sitting areas for cafes and a large carport for 16 vehicles. The material wood offers unlimited possibilities.

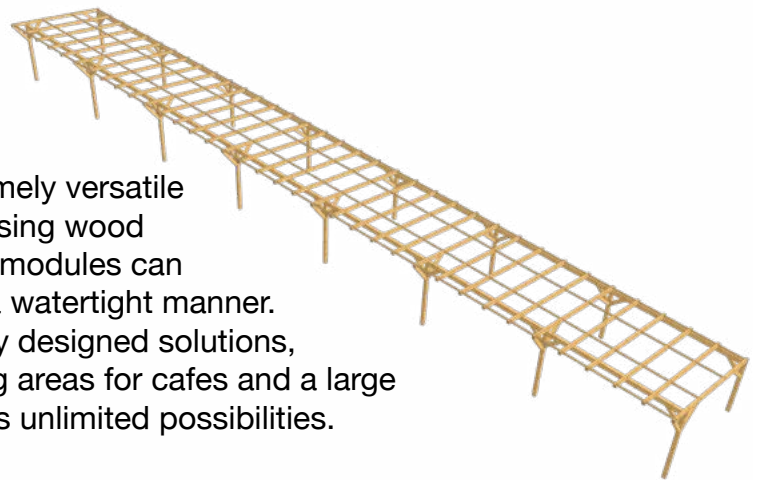

Carport



Terrace



Terrace



Carport



Rooftop



Carport

Wood construction sustainable aesthetic



Wood is a natural and incredibly versatile material. **It fits into our times and into our range of products that is dedicated to sustainability.**

All material used for our kits are treated against worms and fungi but still keep natural appearance. Two coats UV resistant waterproof painting in various colors can be done on request.

With this professionally applied protection, the solid wooden parts are almost indestructible.

We therefore give a 25 year guarantee on the durability of the construction.

The wooden parts are made of construction solid wood (KVR) and therefore are dimensionally stable.

They are fitted with tenons on one side and grooves on the other using a modern joinery machine.

These are then only plugged together and screwed together as required.

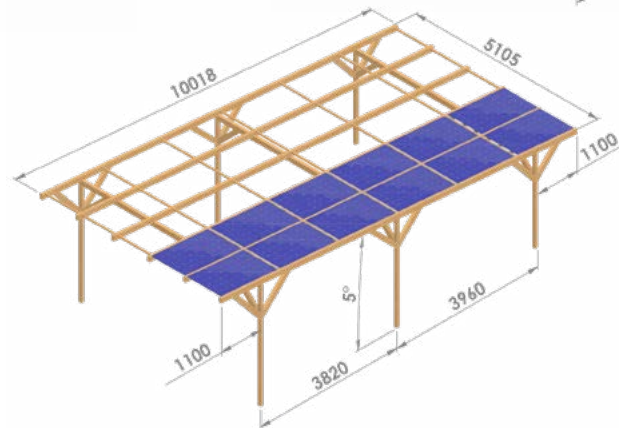
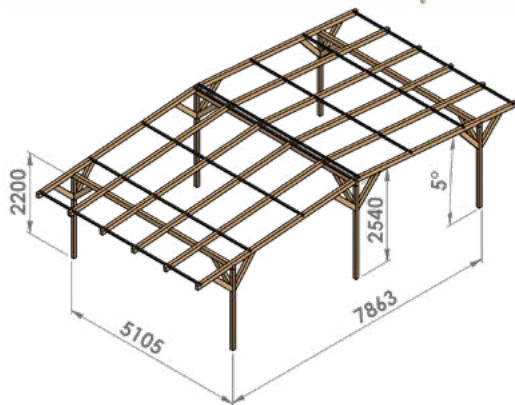
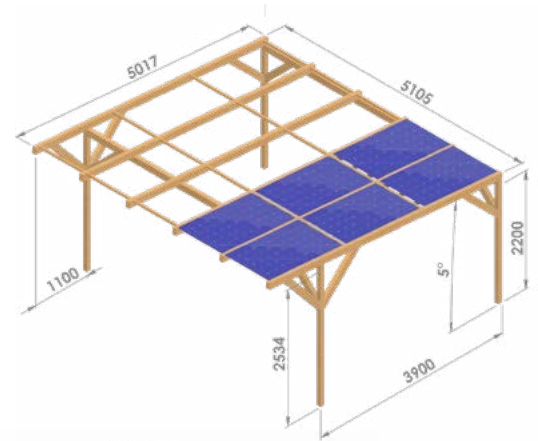
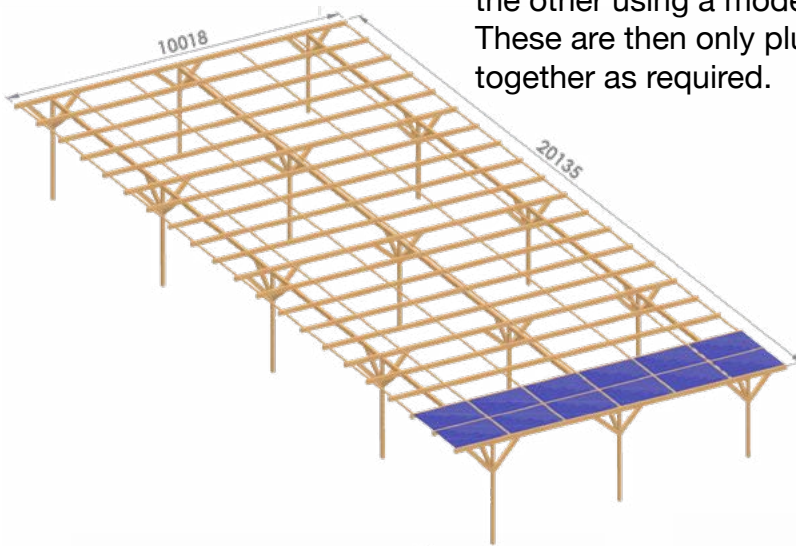

Premium Double Glass PV Modules

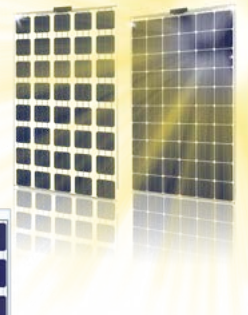

size I

Certificates:



M60
280 Wp



B60
310 Wp

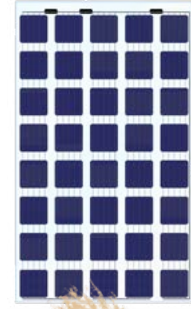

M40
195 Wp

Electrical Specification	M60 280 Wp	B60 310 Wp	M40 195 Wp
Maximum Power at (Pmax)	280 W	310 W	195 W
Optimum Operating Voltage (Vmp)	30.97 V	33.20 V	21.27 V
Optimum Operating Current (Imp)	9.04 A	9.82 A	9.17 A
Open Circuit Voltage (Voc)	38.65 V	40.01 V	26.47 V
Short Circuit Current (Isc)	9.65 A	9.82 A	9.61 A
Module Efficiency	17.0 %	18.8%	11.9%
Maximum System Voltage	1000 V DC (IEC)	1500 V DC (IEC)	1000 V DC (IEC)
Operating Module Temperature	-40 °C to +85 °C	-40 °C to +85 °C	-40 °C to +85 °C
Maximum Series Fuse Rating	20 A	20 A	20 A
Power Tolerance	0 ~ +5 W	0 ~ +5 W	0 ~ +5 W
Dimensions [mm] , approx.	1658 x 992 x 5	1658 x 992 x 5	1658 x 992 x 5

size II

Certificates:



M72
330 Wp



B72
370 Wp

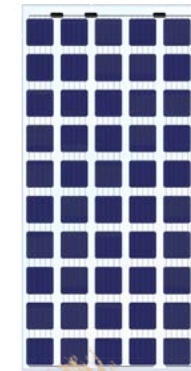

M50
240 Wp

Electrical Specification	M72 330 Wp	B72 370 Wp	M50 240 Wp
Maximum Power at (Pmax)	330 W	370 W	240 W
Optimum Operating Voltage (Vmp)	37.64 V	39.1 V	26.88 V
Optimum Operating Current (Imp)	8.76 A	9.47 A	8.93 A
Open Circuit Voltage (Voc)	47.05 V	47.9 V	32.68 V
Short Circuit Current (Isc)	9.35 A	10.16 A	9.44 A
Module Efficiency	16.8 %	18.9 %	13.0 %
Maximum System Voltage	1000 V DC (IEC)	1000 V DC (IEC)	1000 V DC (IEC)
Operating Module Temperature	-40 °C to +85 °C	-40 °C to +85 °C	-40 °C to +85 °C
Maximum Series Fuse Rating	20 A	15 A	20 A
Power Tolerance	0 ~ +5 W	0 ~ +5 W	0 ~ +5 W
Dimensions [mm] , approx.	1980 x 990 x 5	1980 x 990 x 5	1980 x 990 x 5



Mounting instruction in pictures

The supports must be inserted and aligned in the foundations provided at the beginning of the assembly. The supports should still be movable in order to be able to make any necessary corrections later.



All wooden components are provided with numbers. So put the parts with the same numbers together. This is the basic structure of the wooden construction. The bracing on the posts provides the optimum stability.



Connect all the wooden parts and screw them together.





When you finished the wooden structure you can start to put the modules on top of the construction.

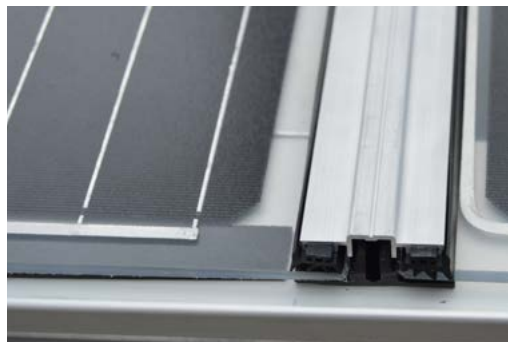

For more information of the module mounting ask for our **Premium Module Mounting Instruction**



Wood Power

**Please contact us for an individual offer that meets your needs.
We are looking forward to your message.**



GridParity AG
next generation photovoltaic

Ohmstr. 7, 85757 Karlsfeld
GERMANY

www.gridparity.ag
info@gridparity.ag

Tel: +49 (0) 8131 3307 560
Fax: +49 (0) 8131 3307 737



other products that might also be interesting for you:



PV Carports



PV Terraces



PV PowerWall



EPC



AgriPV